

30KPA SERIES GLASS PASSIVATED TRANSIENT VOLTAGE SUPPRESSOR

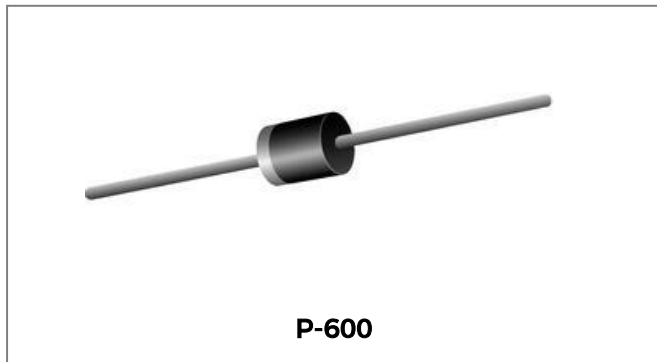

Features

- Plastic package has Underwriters Laboratory Flammability Classification 94V-0
- Glass Passivated Junction
- 30000W Peak Pulse Power Capability on 10/1000 μ s waveform
- Voltage-28.0 to 400 Volts
- Excellent Clamping Capability
- Repetition rate (duty cycle): 0.05%
- Low incremental surge resistance
- Fast Response Time: typically less than 1.0 ps from volts to BV
- High temperature soldering guaranteed: 265°C/10 seconds/.375" (9.5mm) lead length, 5lbs., (2.3kg) tension
- This is a Pb - Free Device
- All SMC Parts are Traceable to the Wafer Lot
- Additional testing can be offered upon request

Mechanical Data

- Case: Molded Plastic over glass passivated junction
- Terminals: Plated Axial leads, Solderable per MIL-STD 750, Method 2026
- Polarity: Color Band denoted positive end (cathode) except Bipolar
- Mounting Position: Any
- Weight: 2.1 grams (approx.)

Circuit Diagram

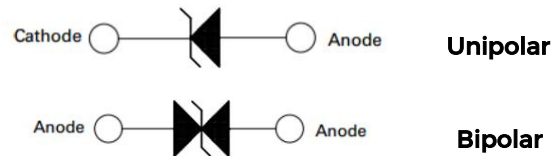

Maximum Ratings and Thermal Characteristics @ $T_A=25^\circ\text{C}$ unless otherwise specified

Parameter	Symbol	Value	Unit
Peak Pulse Power Dissipation on 10x1000 μ s Waveform (Note 1)	P_{PPM}	30000	W
Steady State Power Dissipation at $T_L=75^\circ\text{C}$ Lead Lengths .375" (9.5mm) (Note 2)	$P_{M(AV)}$	8.0	W
Peak Forward Surge Current, 8.3ms Sine-Wave Superimposed on Rated Load, (JEDEC Method) (Note 3)	I_{FSM}	400.0	A
Typical Thermal Resistance Junction to Lead	$R_{\theta JL}$	8.0	$^\circ\text{C/W}$
Typical Thermal Resistance Junction to Ambient	$R_{\theta JA}$	40	$^\circ\text{C/W}$
Operating Junction and Storage Temperature Range	T_J, T_{STG}	-55 to 175	$^\circ\text{C}$

- Notes:**
1. Non-repetitive current pulse, per Fig. 3 and derated above $T_A = 25^\circ\text{C}$ per Fig. 2.
 2. Mounted on copper pad area of 0.8" x 0.8" (20 x 20mm)
 3. 8.3ms single half sine wave, or equivalent square, duty cycle=4 pulses per minute maximum.

Electrical Characteristics @T_A=25°C unless otherwise specified

UNI-POLAR	BI-POLAR	REVERSE STAND-OFF VOLTAGE V _{RWM} (V)	BREAKDOWN VOLTAGE V _{BR} (V) MIN. @I _T	TEST CURREN T I _T (MA)	MAXMUM CLAMPING VOLTAGE @I _{PP} V _C (V)	PEAK PULSE CURRENT I _{PP} (A)	REVERSE LEAKAGE @V _{RWM} I _R (uA)
30KPA28A	30KPA28CA	28	31.3	50	50	606	5000
30KPA30A	30KPA30CA	30	33.5	50	55.2	548.9	5000
30KPA33A	30KPA33CA	33	36.9	50	58.5	517.2	5000
30KPA36A	30KPA36CA	36	40.2	50	61.8	490.3	5000
30KPA39A	30KPA39CA	39	43.6	20	67.2	450.9	2000
30KPA42A	30KPA42CA	42	46.9	10	72	420.8	1000
30KPA43A	30KPA43CA	43	48	10	73	415.1	1000
30KPA45A	30KPA45CA	45	50.3	5	77.4	391.5	250
30KPA48A	30KPA48CA	48	53.6	5	81.6	371.3	150
30KPA51A	30KPA51CA	51	57	5	86.4	350.7	50
30KPA54A	30KPA54CA	54	60.3	5	91.4	331.5	20
30KPA58A	30KPA58CA	58	64.8	5	92.4	327.9	20
30KPA60A	30KPA60CA	60	67	5	102	297.1	15
30KPA64A	30KPA64CA	64	71.5	5	104	291.3	10
30KPA66A	30KPA66CA	66	73.7	5	107	283.2	10
30KPA70A	30KPA70CA	70	78.2	5	109	278	10
30KPA71A	30KPA71CA	71	79.3	5	111.5	271.7	10
30KPA72A	30KPA72CA	72	80.4	5	114	265.8	10
30KPA75A	30KPA75CA	75	83.8	5	119.4	253.8	10
30KPA78A	30KPA78CA	78	87.1	5	129	234	10
30KPA84A	30KPA84CA	84	93.8	5	139.2	217.7	10
30KPA90A	30KPA90CA	90	100.5	5	146.4	207	10
30KPA96A	30KPA96CA	96	107.2	5	156	194.2	10
30KPA102A	30KPA102CA	102	113.9	5	165.6	183	10
30KPA108A	30KPA108CA	108	120.6	5	175.2	172.9	10
30KPA120A	30KPA120CA	120	134	5	194.4	155.9	10
30KPA132A	30KPA132CA	132	147.4	5	213	142.3	10
30KPA144A	30KPA144CA	144	160.8	5	223.2	135.8	10
30KPA150A	30KPA150CA	150	167.6	5	233.4	129.8	10
30KPA156A	30KPA156CA	156	174.3	5	245	123.7	10
30KPA160A	30KPA160CA	160	178.7	5	252.6	120	10
30KPA168A	30KPA168CA	168	187.7	5	272.4	111.2	10
30KPA170A	30KPA170CA	170	189.9	5	275	110.2	10
30KPA180A	30KPA180CA	180	201.1	5	290.4	104.3	10
30KPA198A	30KPA198CA	198	221.2	5	319.8	94.7	10
30KPA216A	30KPA216CA	216	241.3	5	348.6	86.9	10
30KPA240A	30KPA240CA	240	268.1	5	387	78.3	10
30KPA258A	30KPA258CA	258	288.2	5	416.4	72.8	10
30KPA260A	30KPA260CA	260	290.4	5	416	72.8	10
30KPA270A	30KPA270CA	270	301.6	5	436.2	69.5	10
30KPA280A	30KPA280CA	280	312.8	5	464	65.3	10
30KPA288A	30KPA288CA	288	321.7	5	469.9	64.5	10
30KPA300A	30KPA300CA	300	333	5	483	62	10
30KPA350A	30KPA350CA	350	389	5	564	53	10
30KPA400A	30KPA400CA	400	444	5	644	46	10

For bidirectional type having V_{RWM} of 40 volts and less, the I_R limit is double.
For parts without A, the V_{BR} is + 10% and V_C is 5% higher than with A parts.

Ratings and Characteristics Curves

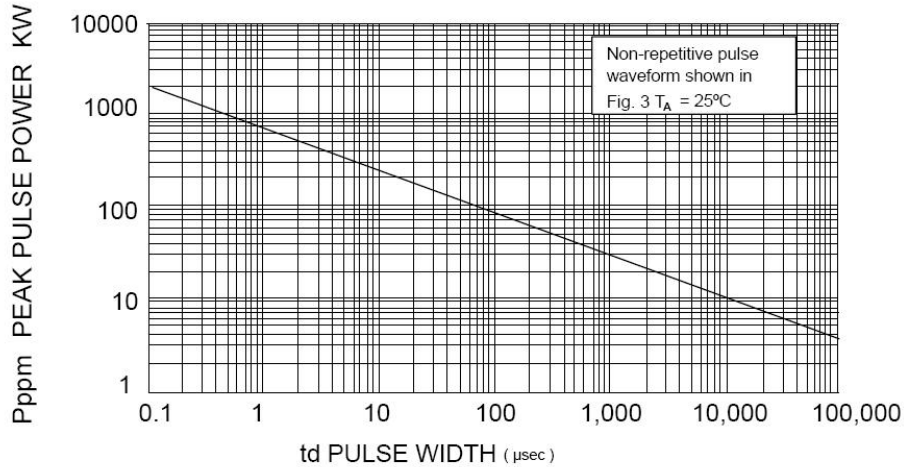

FIG. 1 PEAK PULSE POWER RATING

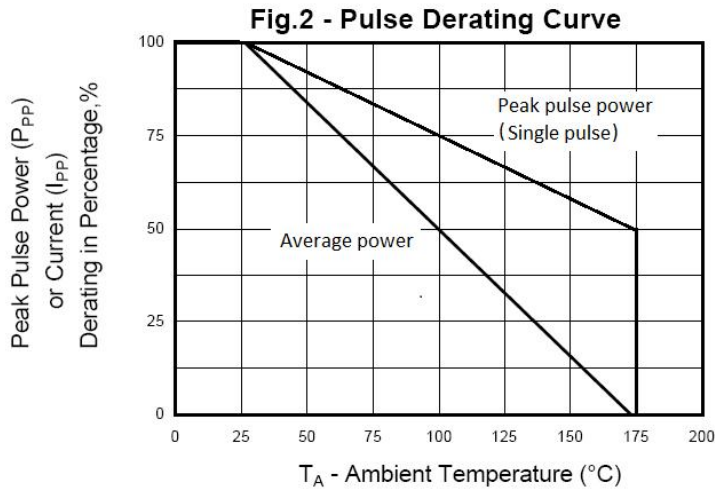

Fig.2 - Pulse Derating Curve

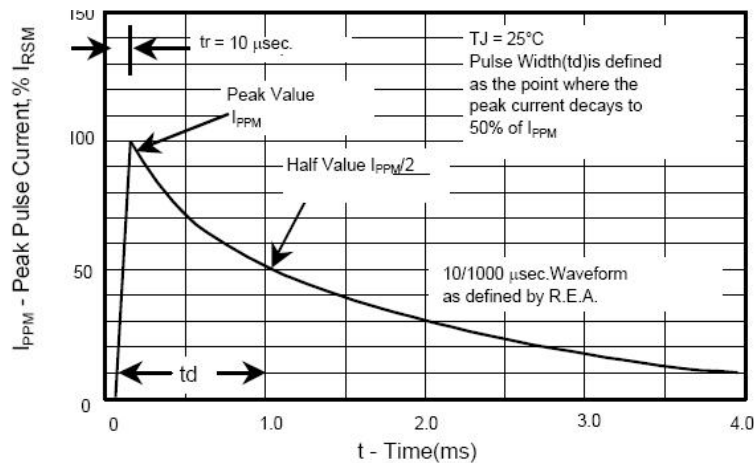
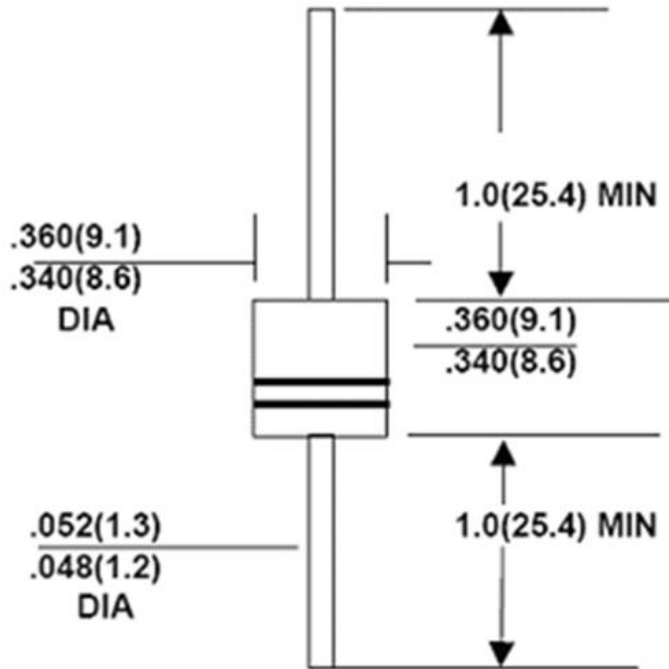

Fig.3 - Pulse Waveform

Mechanical Dimensions P-600(Inches/Millimeters)



Ordering Information

Device	Package	Shipping
30KPAxxxXX	P-600(Pb-Free)	300pcs /tape
30KPAxxxXXTR	P-600(Pb-Free)	800pcs / reel

For information on tape and reel specifications, including part orientation and tape sizes, please refer to our tape and reel packaging specification.

Marking Diagram



Where XXXXX is YYWWL

30KPA28A = Part Name
YY = Year
WW = Week
L = Lot Number

Cautions: Molding resin
Epoxy resin UL:94V-0

Carrier Tape Specification P-600

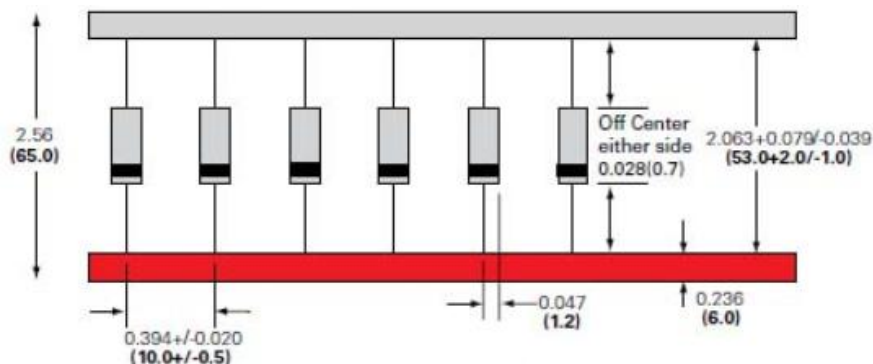



DISCLAIMER:

- 1- The information given herein, including the specifications and dimensions, is subject to change without prior notice to improve product characteristics. Before ordering, purchasers are advised to contact the SMC Diode Solutions sales department for the latest version of the datasheet(s).
- 2- In cases where extremely high reliability is required (such as use in nuclear power control, aerospace and aviation, traffic equipment, medical equipment, and safety equipment), safety should be ensured by using semiconductor devices that feature assured safety or by means of users' fail-safe precautions or other arrangement.
- 3- In no event shall SMC Diode Solutions be liable for any damages that may result from an accident or any other cause during operation of the user's units according to the datasheet(s). SMC Diode Solution assumes no responsibility for any intellectual property claims or any other problems that may result from applications of information, products or circuits described in the datasheets.
- 4- In no event shall SMC Diode Solutions be liable for any failure in a semiconductor device or any secondary damage resulting from use at a value exceeding the absolute maximum rating.
- 5- No license is granted by the datasheet(s) under any patents or other rights of any third party or SMC Diode Solutions.
- 6- The datasheet(s) may not be reproduced or duplicated, in any form, in whole or part, without the expressed written permission of SMC Diode Solutions.
- 7- The products (technologies) described in the datasheet(s) are not to be provided to any party whose purpose in their application will hinder maintenance of international peace and safety nor are they to be applied to that purpose by their direct purchasers or any third party. When exporting these products (technologies), the necessary procedures are to be taken in accordance with related laws and regulations..